

Standard design

LKB is available in three versions, LKB for ISO and DIN tubes, LKB-2 for DIN tubes and LKB-F for flange connection.

The valve consists of two valve body halves, valve disc, bushes for the disc stem and seal ring. LKB-F also consists of two flanges and two flange seal rings. The valve is assembled by means of screws and nuts.

Two actuator sizes, $\varnothing 85$ mm and $\varnothing 133$ mm, cover all valve sizes. The actuator is available in two versions, LKLA and LKLA-T.

The actuator is fitted onto the valve by means of a bracket and screws. (The actuator can also be fitted onto ball valves by means of special brackets).

The handle for manual operation is fitted onto the valve by means of a cap/block system and a screw.

The valve has welding ends as standard, but LKB and LKB-2 can also be supplied with fittings.

Options

- A. Male parts or clamp liners in accordance with required standard.
 - B. ThinkTop® for control and indication.*
 - C. Indication unit with micro switches.*
 - D. Indication unit with inductive proximity switches.*
 - E. Indication unit with Hall proximity switches.*
 - F. Explosion proof indication unit with inductive proximity switches.*
 - G. Bracket for actuator. (Also for ball valves).
 - H. Handle with two or four positions (standard on DN125 and DN150).
 - I. Handle for electrical position indication.
 - J. Handle with infinite intermediate positions (not for DN125 and DN150).
 - K. Multipositioning handle**.
 - L. Lockable Multiposition Handle. Padlock can be mounted as shown in fig. 3.
- Note!** Padlock is not delivered.
- M. Special cap for 90° turned handle position.
 - N. Service tool for actuator.
 - O. Service tool for fitting 25-38 mm (DN25 - DN40) valve discs.
- * For further information see Product Catalogue chapter "Control & Indication".
- ** A padlock can be mounted on the Lockable Multiposition Handle as shown in the opposite figure.
- Note!** Padlock is not delivered.

Note!

For further details, see also ESE02446.

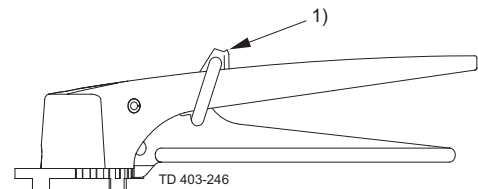

Fig. 1. Lockable Multiposition Handle with padlock.

1. Padlock

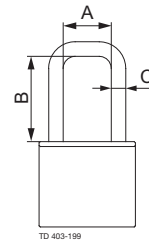

Fig. 2. Dimensions - padlock.

- A. Min. 20 mm
- B. Min. 35 mm
- C. $\varnothing 6$ mm

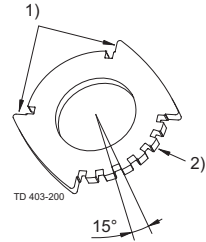
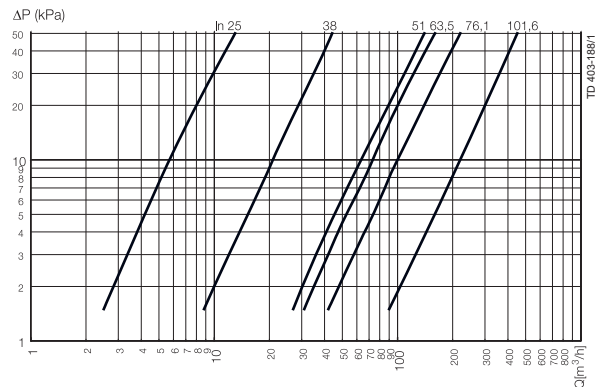

Fig. 3. Positioning cap.

- 1. On/Off
- 2. Multi positioning

Capacity/Pressure drop diagrams



LKB and LKB-F fully open

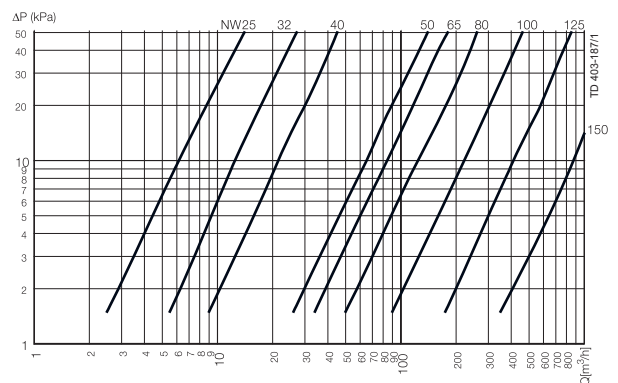

LKB-2 and LKB-F fully open

NOTE!

For the diagrams the following applies:

Medium: Water (20°C)(68°F).

Measurement: In accordance with VDI 2173.

Torque diagrams - Actuator

LKLA \varnothing 85 mm:
NC

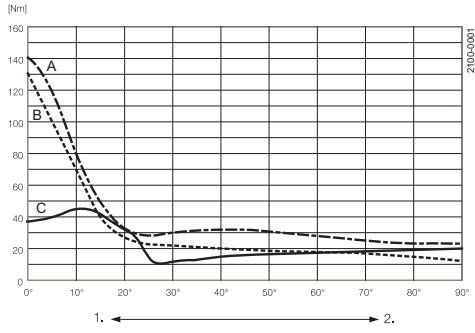

1. Closing - Spring activated 2. Opening - Air activated

LKLA \varnothing 133 mm:
NC

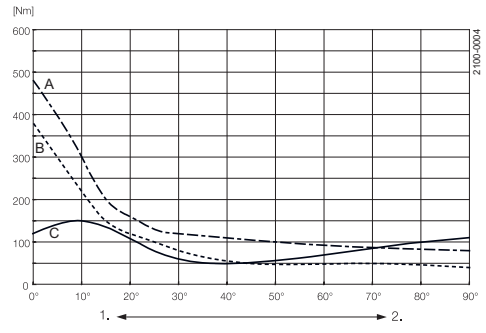

1. Closing - Spring activated 2. Opening - Air activated

NO

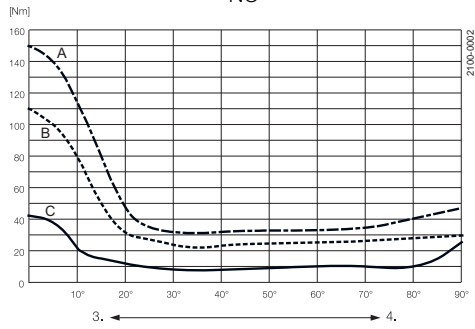

3. Closing - Air activated 4. Opening - Spring activated

NO

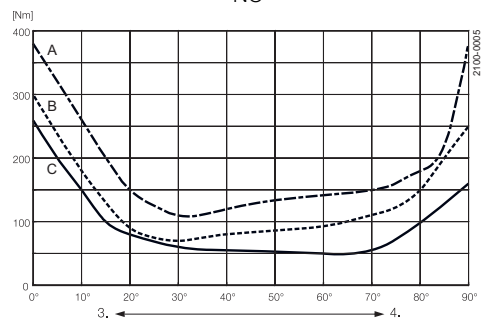

3. Closing - Air activated 4. Opening - Spring activated

A/A

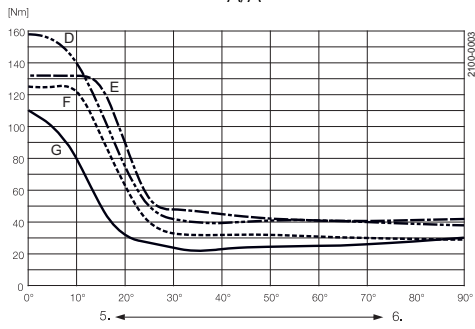

5. Closing 6. Opening

A/A

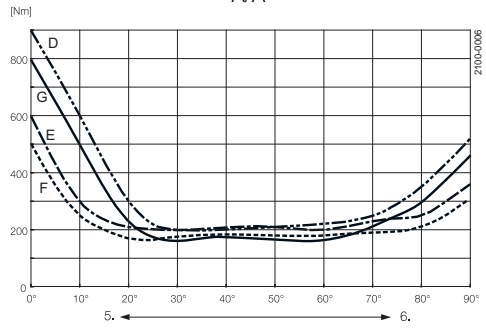

5. Closing 6. Opening

- A = 6 bar air pressure
- B = 5 bar air pressure
- C = Closing/opening with spring

- D = 6 bar air pressure connection on top
- E = 6 bar air pressure connection on bottom
- F = 5 bar air pressure connection on top
- G = 5 bar air pressure connection on bottom

Alfa Laval recommends actuator size \varnothing 133 for $\geq 101.6/DN100$

Torque values (for rotating the valve disc in a dry seal ring)

Size	Max. Nm
25mm/DN25	15
DN32	15
38mm/DN40	15
51mm/DN50	20
63.5mm/DN65	25
76mm/DN80	30
101.6mm/DN100	35
DN125	50
DN150	120

Valve Dimensions (mm)

Fig. 1. Dimensions - valve.

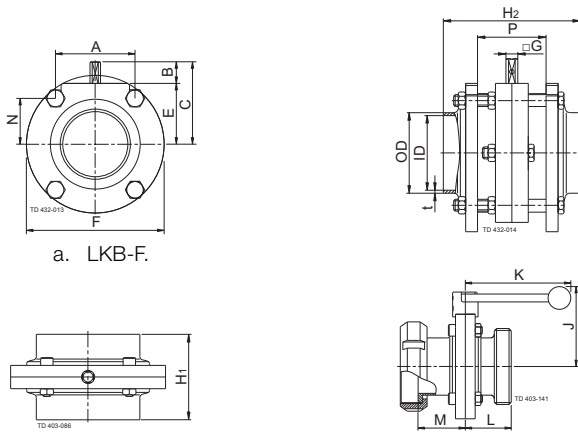

a. LKB-F.

b. LKB with welding ends.

Note! LKB sizes DN 125 and

150 are with six screws.

c. LKB with male part/nut and liner.

Fig. 2. Dimensions - actuator

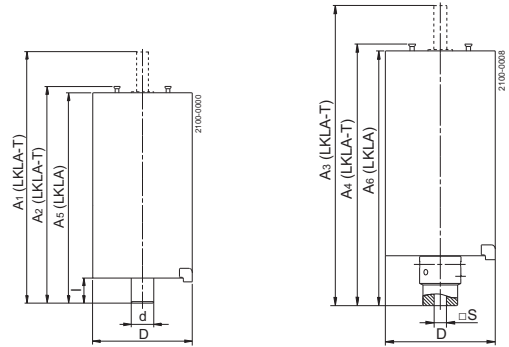

a. Without coupling.

a1 = d

b. With coupling.

b1 = □S

Dimensions (mm) - Valve

LKB, LKB-2, LKB-F:

Size	25	38	51	63.5	76.1	101.6	DN	DN	DN	DN	DN	DN	DN	DN	DN
	mm	mm	mm	mm	mm	mm	25	32	40	50	65	80	100	125	150
A	42.0	42.0	61.0	61.0	79.5	106.0	42.0	42.0	42.0	61.0	61.0	79.0	106.0	106.0	98.0
B	15.5	16.7	16.6	17.5	16.6	16.0	14.7	15.9	16.7	16.6	17.5	16.0	16.0	18.0	18.0
C	49.0	49.0	58.5	69.5	73.5	93.0	48.0	49.0	54.0	63.0	75.0	79.0	93.0	115.0	122.0
OD	25.6	38.6	51.6	64.1	76.6	102.2	30.0	36.0	42.0	54.0	70.0	85.0	104.0	129.0	154.0
ID	22.5	35.5	48.5	60.5	72.0	97.6	26.0	32.0	38.0	50.0	66.0	81.0	100.0	125.0	150.0
t	1.55	1.55	1.55	1.8	2.3	2.3	2.0	2.0	2.0	2.0	2.0	2.0	2.0	2.0	2.0
E	32.5	32.5	42.0	52.0	57.0	77.0	33.3	33.3	37.7	46.6	57.3	63.0	77.0	96.7	104.0
F	78.0	78.0	99.0	117.0	132.0	169.0	79.0	79.0	86.5	105.7	125.0	143.0	169.0	199.0	216.0
G	8.0	8.0	8.0	8.0	10.0	12.0	8.0	8.0	8.0	8.0	10.0	10.0	12.0	14.0	15.0
H ₁	47.0	47.0	52.0	54.0	62.0	80.0	47.0	47.0	47.0	52.0	62.0	64.0	80.0	110.0	80.0
H ₂	83.0	83.0	92.0	92.0	114.0	132.0	83.0	83.0	83.0	92.0	114.0	116.0	132.0	136.0	152.0
J	82.0	82.0	92.0	102.0	107.0	127.0	74.0	74.0	78.0	88.0	98.0	104.0	118.0	150.0	161.0
K	120.0	120.0	120.0	120.0	162.0	162.0	120.0	120.0	120.0	120.0	162.0	162.0	162.0	223.0	338.0
L IDF/ISO	45.0	45.0	47.5	48.5	52.5	61.5	-	-	-	-	-	-	-	-	-
M IDF/ISO	55.5	55.5	58.0	59.0	63.0	81.5	-	-	-	-	-	-	-	-	-
L DS	42.0	43.5	46.0	51.0	55.0	64.0	-	-	-	-	-	-	-	-	-
M DS	54.5	54.5	57.0	59.0	63.0	72.0	-	-	-	-	-	-	-	-	-
L SMS	38.5	43.5	46.0	51.0	55.0	75.0	-	-	-	-	-	-	-	-	-
M SMS	51.0	52.5	55.0	56.0	61.0	72.0	-	-	-	-	-	-	-	-	-
L BS	45.7	45.7	48.2	49.2	53.2	67.0	-	-	-	-	-	-	-	-	-
M BS	50.5	50.5	53.0	54.0	58.0	71.8	-	-	-	-	-	-	-	-	-
L DIN	45.5	45.5	48.0	52.0	61.0	70.0	40.0	40.0	37.0	37.0	43.0	48.0	51.0	55.0	115.0
M DIN	61.5	61.5	66.0	67.0	71.0	83.0	45.5	48.5	49.5	54.0	63.0	69.0	84.0	89.0	77.0
L Clamp	45.0	45.0	47.5	48.5	52.5	61.5	45.0	45.0	45.0	47.5	59.0	60.0	68.0	83.0	68.0
N	26.5	26.5	30.5	40.5	43.5	53.0	27.3	27.3	31.7	35.1	45.8	49.5	53.0	72.7	85.0
P	42.0	42.0	46.0	46.0	58.0	58.0	42.0	42.0	42.0	46.0	58.0	58.0	58.0	62.0	78.0
Weight LKB-F (kg)	1.6	1.3	2.1	2.9	5.0	7.9	1.6	1.6	1.7	2.6	4.7	5.8	7.9	11.7	12.3
Weight LKB/ LKB-2 (kg)	1.2	1.0	1.5	2.1	3.0	4.7	1.2	1.1	1.3	1.8	3.0	3.5	5.1	7.5	9.0

NOTE! Weights are for valves with welding ends and handles.

Dimensions (mm) - Actuator**LKLA and LKLA-T:**

Valve size	25-63.5 DN25-50	76.1 DN65-80	101.6 DN100	101.6 DN100	DN125	DN125	DN150	DN150
A ₁	217.1	217.1	217.1	337	217.1	337	217.1	337
A ₂	173.5	173.5	173.5	290	173.5	290	173.5	290
A ₃	236.1	234.1	234.1	363.5	237.1	363.5	237.1	363.5
A ₄	192.5	190.5	190.5	316.5	193.5	316.5	193.5	316.5
A ₅	165.5	165.5	165.5	282	165.5	282	165.5	282
A ₆	184.5	182.5	182.5	308.5	185.5	308.5	185.5	308.5
D	85	85	85	133	85	133	85	133
d	17	17	17	30	20	30	20	30
l	16.5	16.5	16.5	34	16.5	34	16.5	34
S	8	10	12	12	14	14	15	15
Function	NC,NO,A/A	NC,NO,A/A	NC,NO,A/A	NC,NO,A/A	A/A	NC,NO,A/A	A/A	NC,NO,A/A

Connections**Compressed air**

R1/8" (BSP), internal thread.

Alfa Laval reserves the right to change specifications without prior notification.

How to contact Alfa Laval

Contact details for all countries
are continually updated on our website.
Please visit www.alfalaval.com to
access the information direct.