



Alfa Laval Safety Valve

Safeguarding your system

Concept

The Alfa Laval Safety Valve is a spring loaded safety valve used to prevent overpressure in tanks and vessels in the dairy, food and beverage, and biopharm industries to reliably avoid damages to human beings and equipment.

Working principle

It is used to prevent inadmissible over pressures of fluids in tanks, containers and plant sections. From the factory the valve is configured with a set pressure upon request that is greater than the operating pressure. The valve opens against a spring force if the operating pressure increases the set pressure. Preferably, the Alfa Laval Safety Valve should be installed vertically. If mounted horizontal the set pressure will be a bit lower than specified due to the missing weight of the piston. Highest effect on DN80 and DN100.

Standard Design

The Alfa Laval Safety Valve comes in sizes from DN25 to DN100 with spring loaded set pressure range from 0.2 to 12 bar. The valve can be pneumatic or manually operated. Alfa Laval Safety Valve is delivered with PED certificate. Compliance to EN 4126-1 Compliance to PED 2014/68/EC of the European Community. Fluid group II (Non-hazardous fluids).

The safety valve is available for both liquids and gases*

TECHNICAL DATA

Temperature

Temperature range: +5°C to +95 °C

Max. sterilisation temperature, dry steam: . . .140 °C

*DN25 for gas applications is only available for set pressure up to 1.5 bar



PHYSICAL DATA

Materials

Product wetted parts: 1.4404 (316L)

Other steel parts: 1.4301 (304)

Seals: EPDM

External finish: Ra 1.5-2.5 µm

Internal finish Ra 0.8 µm

Connections: Liner/nut - male DIN 11851

Option:

Inductive sensor for feedback is available for standard and pneumatic lifting - see instruction manual for detail.

Dimensions:

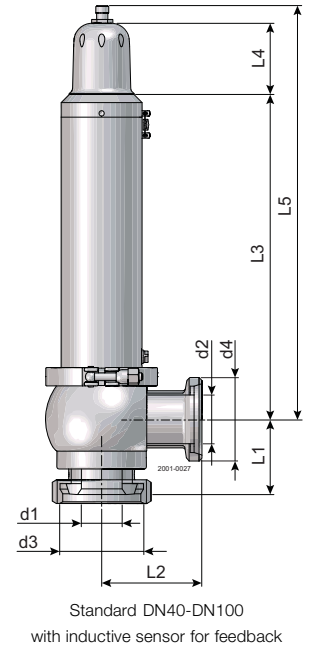
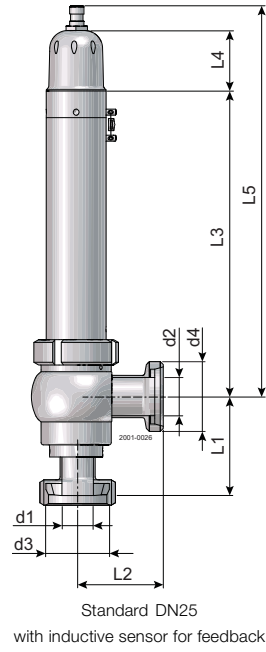
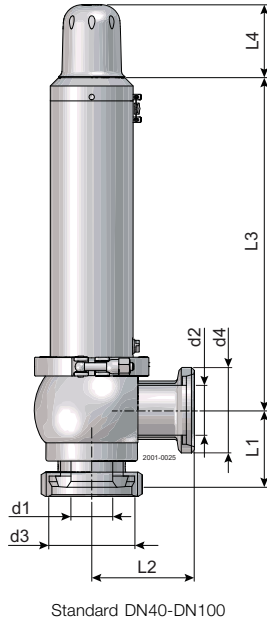
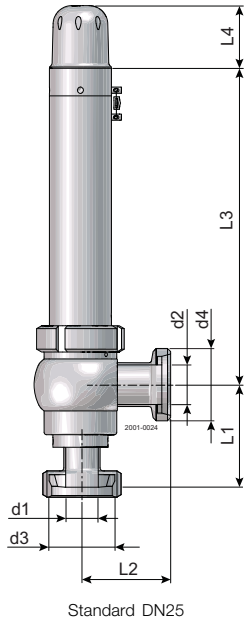

Standard

Size	d1	d2	d3	d4	L1	L2	L3	L4	Kg
DN25	26	32	Rd52x1/6	Rd58x1/6	82	72	253	50	6.8
DN40	32	38	Rd65x1/6	Rd65x1/6	68	82	255	66	9.1
DN50	38	50	Rd78x1/6	Rd78x1/6	70	93	301	66	1.3
DN65	50	66	Rd95x1/6	Rd95x1/6	85	105	402	66	15.0
DN80	66	81	Rd110x1/4	Rd110x1/4	100	115	407.5	66	22.0
DN100	81	100	Rd130x1/4	Rd130x1/4	130	130	418	66	28.2

Standard with inductive sensor for feedback

Size	d1	d2	d3	d4	L1	L2	L3	L4	L5	Kg
DN25	26	32	Rd52x1/6	Rd58x1/6	82	72	253	50	324	6.8
DN40	32	38	Rd65x1/6	Rd65x1/6	68	82	255	66	338	9.1
DN50	38	50	Rd78x1/6	Rd78x1/6	70	93	301	66	384	1.3
DN65	50	66	Rd95x1/6	Rd95x1/6	85	105	402	66	484	15.0
DN80	66	81	Rd110x1/4	Rd110x1/4	100	115	407.5	66	489	22.0
DN100	81	100	Rd130x1/4	Rd130x1/4	130	130	418	66	501	28.2

Dimensions:

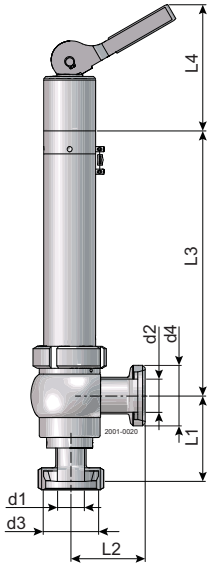

Manual lifting DN25

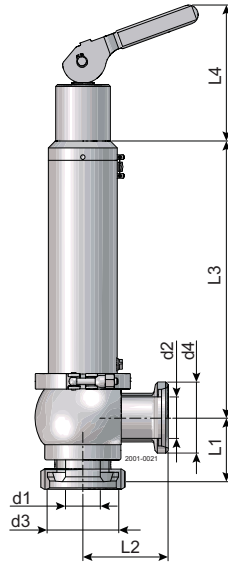

Manual lifting DN40-DN100

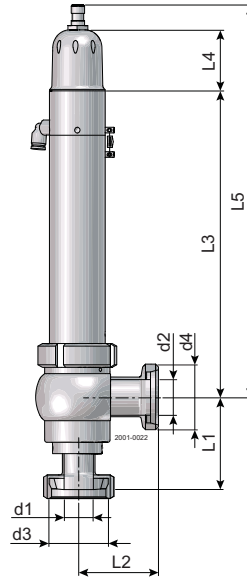

Pneumatic lifting DN25
with inductive sensor for feedback

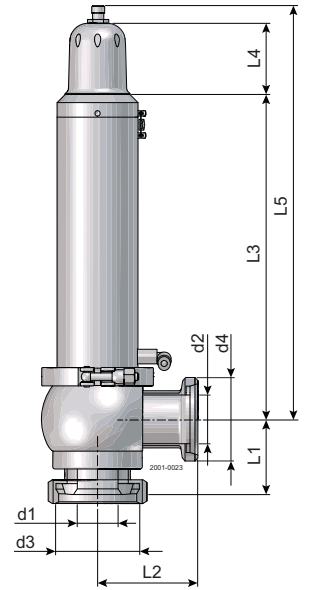

Pneumatic lifting DN40-DN100
with inductive sensor for feedback

Manual lifting

Size	d1	d2	d3	d4	L1	L2	L3	L4	Kg
DN25	26	32	Rd52x1/6	Rd58x1/6	82	72	253	141-182	7.5
DN40	32	38	Rd65x1/6	Rd65x1/6	68	82	255	152-232	10.3
DN50	38	50	Rd78x1/6	Rd78x1/6	70	93	301	154-234	15.5
DN65	50	66	Rd95x1/6	Rd95x1/6	85	105	402	153-233	16.2
DN80	66	81	Rd110x1/4	Rd110x1/4	100	115	407.5	152.5-232.5	23.2
DN100	81	100	Rd130x1/4	Rd130x1/4	130	130	418	152-232	29.6

Pneumatic lifting with inductive sensor for feedback

Size	d1	d2	d3	d4	L1	L2	L3	L4	L5	Kg
DN25	26	32	Rd52x1/6	Rd58x1/6	82	72	253	50	324	6.8
DN40	32	38	Rd65x1/6	Rd65x1/6	68	82	255	66	338	9.1
DN50	38	50	Rd78x1/6	Rd78x1/6	70	93	301	66	384	1.3
DN65	50	66	Rd95x1/6	Rd95x1/6	85	105	402	66	484	15
DN80	66	81	Rd110x1/4	Rd110x1/4	100	115	407.5	66	489	22
DN100	81	100	Rd130x1/4	Rd130x1/4	130	130	418	66	501	28.2

Opening and closing characteristics for incompressible fluids (Liquid)

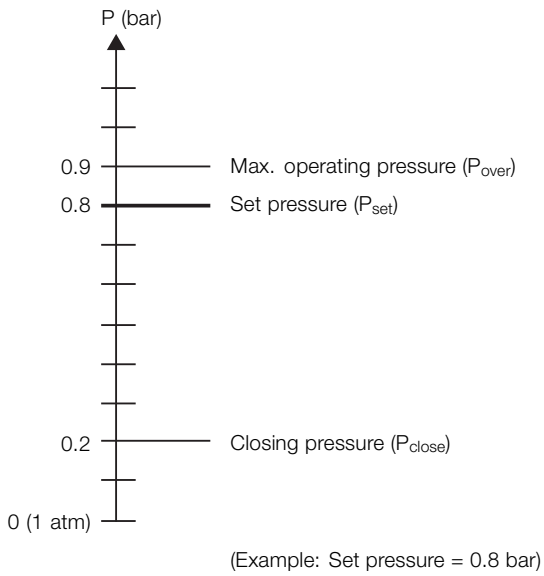

Max. operating pressure (P_{over}):
10 % of set pressure or 0.1 bar, whichever is the greater.

Closing pressure (P_{close}):
Maximum 20% or 0.6 bar below set pressure, whichever is the greater

Opening and closing characteristics for compressible fluids (Gas)

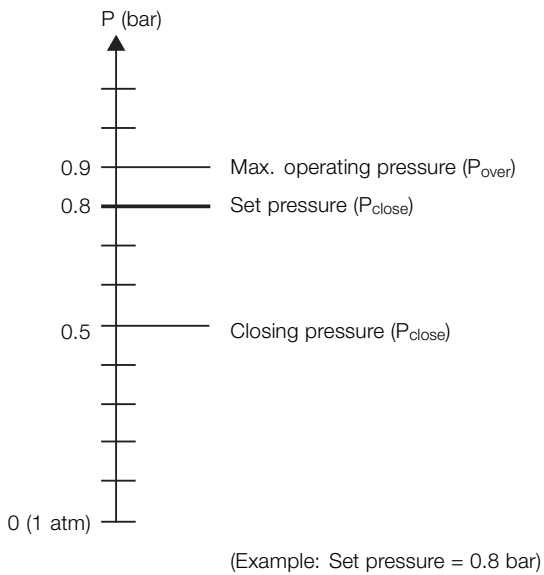

Max. operating pressure (P_{over}):
10 % of set pressure or 0.1 bar, whichever is the greater.

Closing pressure (P_{close}):
Maximum 15% or 0.3 bar below set pressure, whichever is the greater

Blow-off performance chart

DN25 set pressure: 0.2 - 12.0 bar for liquids (water 20 °C)

Flow rate [m³/h].

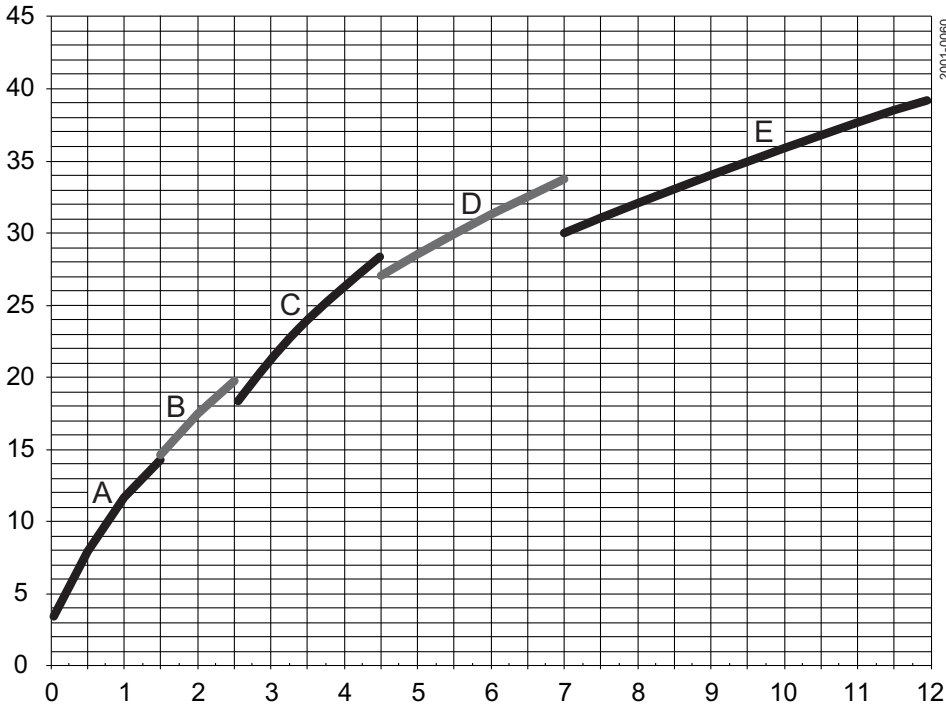

Pressure range [bar]

A = 0.5 - 1.5

B = 1.6 - 2.5

C = 2.6 - 4.5

D = 4.6 - 7.0

E = 7.1 - 12.0

]

Set pressure (bar)

DN 25 set pressure: 0.2 - 1.5 bar for gases (air 20 °C)

Flow rate [m³/h].

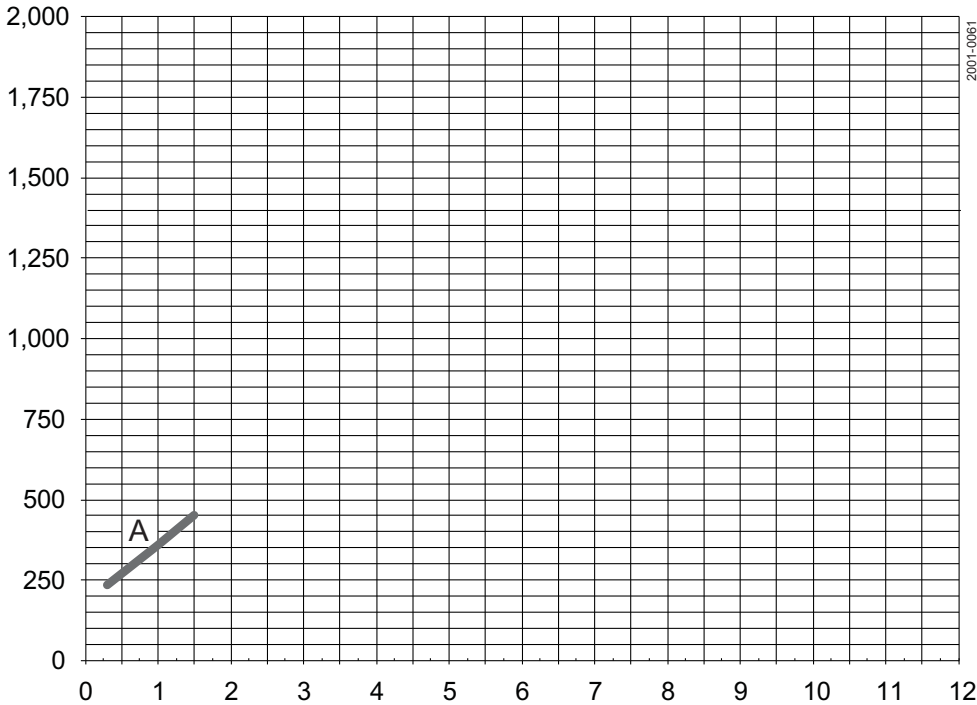

Pressure range [bar]

A = 0.2 - 1.5

Set pressure (bar)

Blow-off performance chart

DN 40 set pressure: 0.2 - 12.0 bar for liquids (water 20 °C)

Flow rate [m³/h].

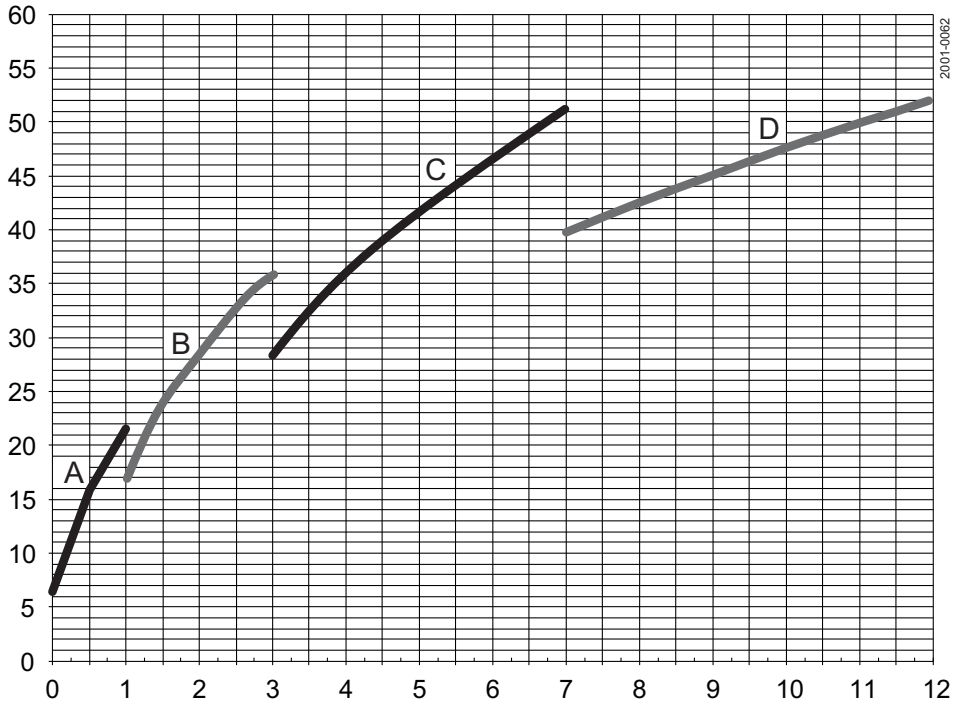

Pressure range [bar]

A = 0.2 - 1.0

B = 1.1 - 3.0

C = 3.1 - 7.0

D = 7.1 - 12.0

ne

Set pressure (bar)

DN 40 set pressure: 0.2 - 12.0 bar for gases (air 20 °C)

Flow rate [m³/h].

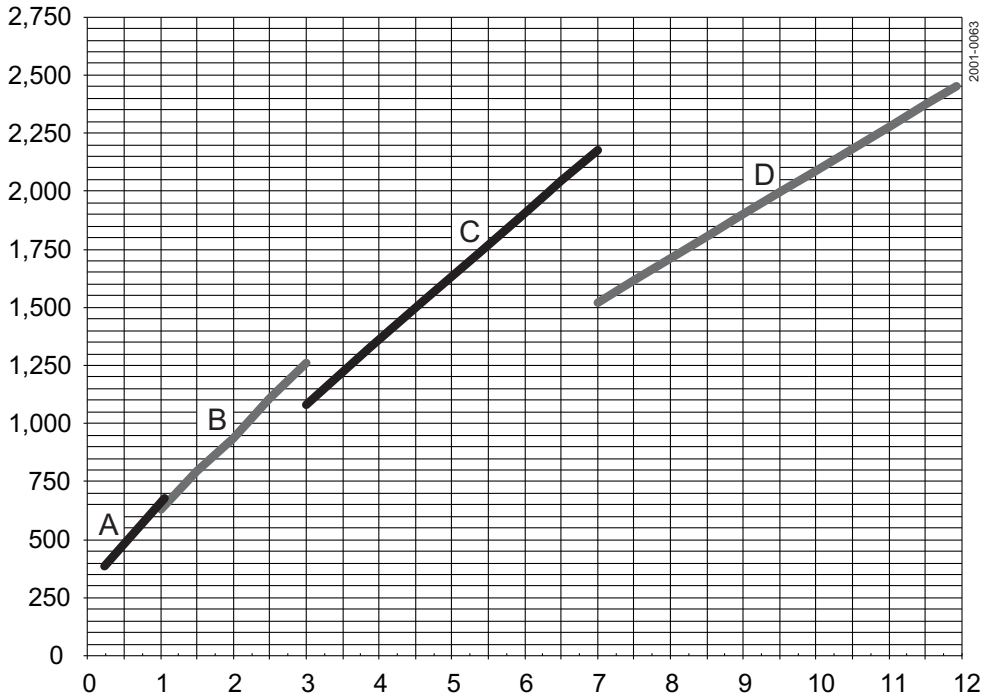

Pressure range [bar]

A = 0.2 - 1.0

B = 1.1 - 3.0

C = 3.1 - 7.0

D = 7.1 - 12.0

Set pressure (bar)

Blow-off performance chart

DN 50 set pressure: 0.3 - 12.0 bar for liquids (water 20 °C)

Flow rate [m³/h].

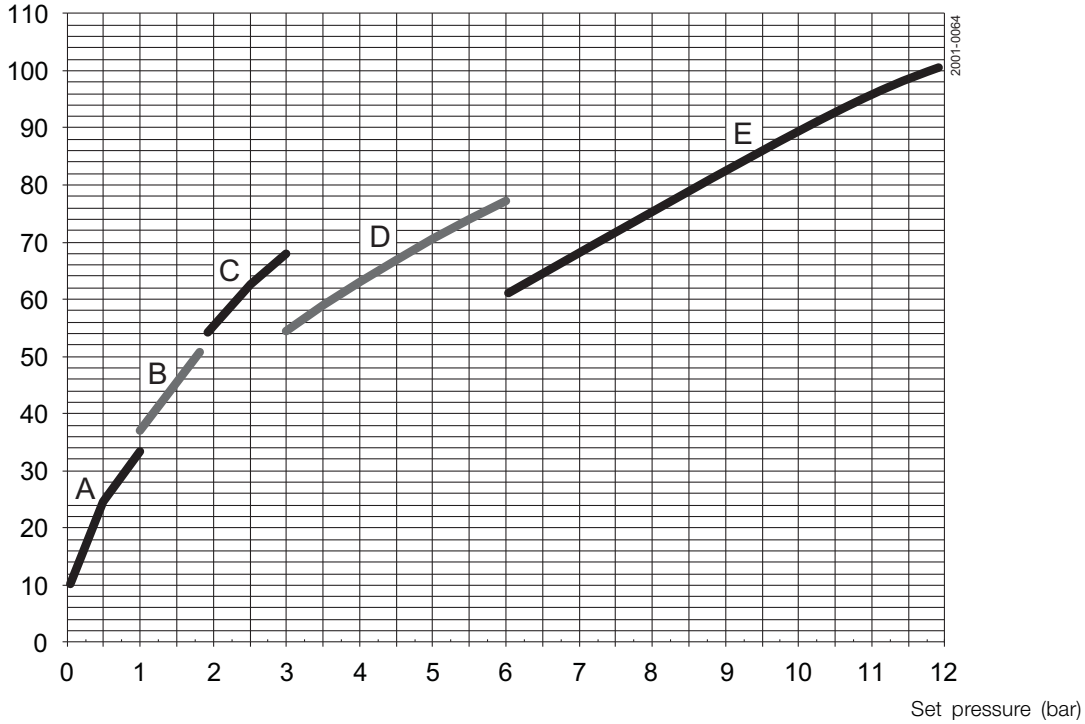

Pressure range [bar]

A = 0.3 - 0.9

B = 1.0 - 1.7

C = 1.8 - 2.9

D = 3.0 - 6.0

E = 6.1 - 12.0

DN50 set pressure: 0.3 - 12.0 bar for gases (air 20 °C)

Flow rate [m³/h].

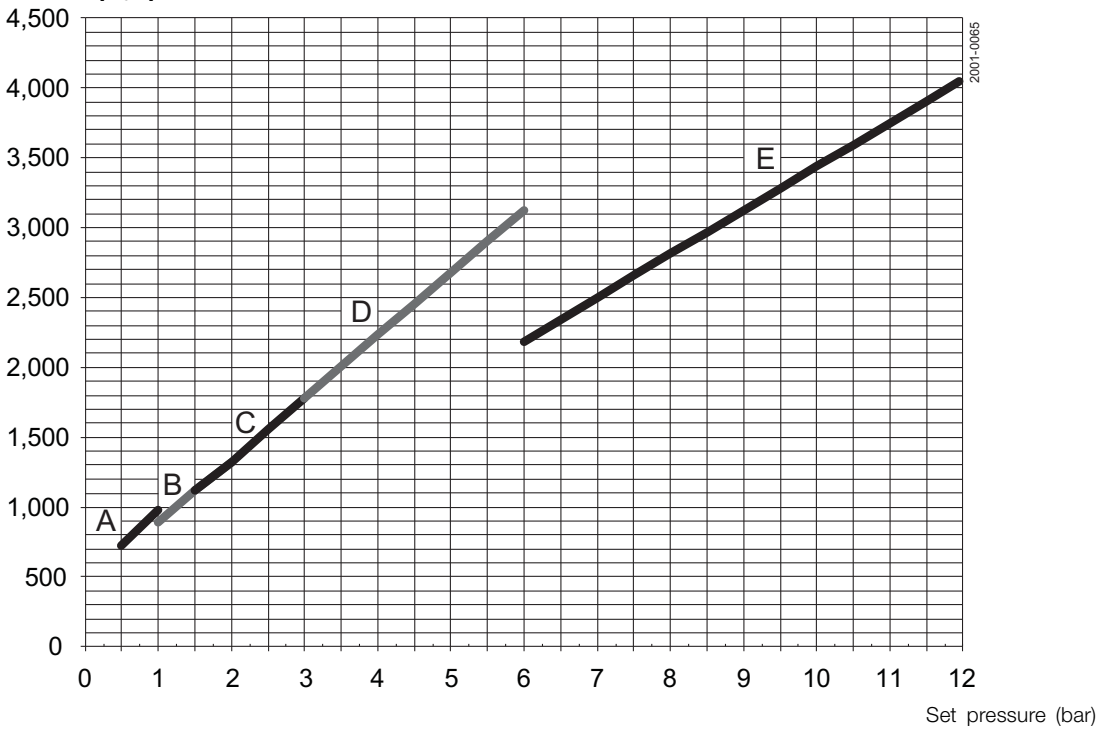

Pressure range [bar]

A = 0.3 - 0.9

B = 1.0 - 1.7

C = 1.8 - 2.9

D = 3.0 - 6.0

E = 6.1 - 12.0

DN65 set pressure: 0.4 - 9.0 bar for liquids (water 20 °C)

Flow rate [m³/h].

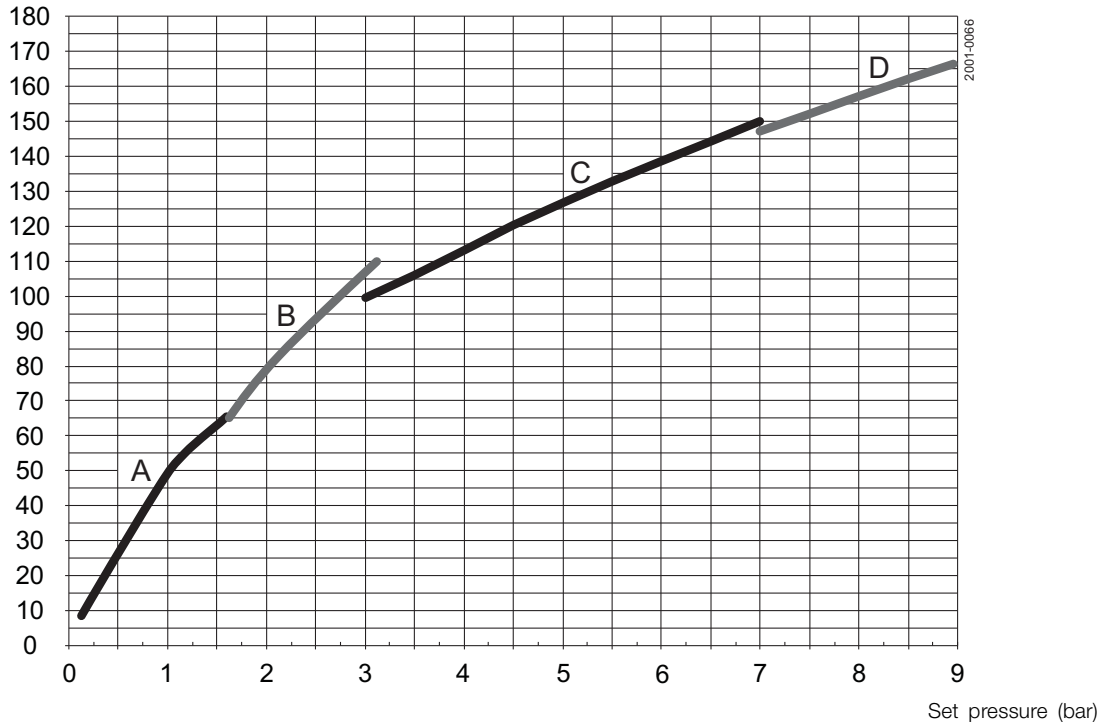

Pressure range [bar]

- A = 0.4 - 1.5
- B = 1.5 - 3.0
- C = 3.1 - 7.0
- D = 7.1 - 9.0

DN65 set pressure: 0.4 - 9.0 bar for gases (air 20 °C)

Flow rate [m³/h].

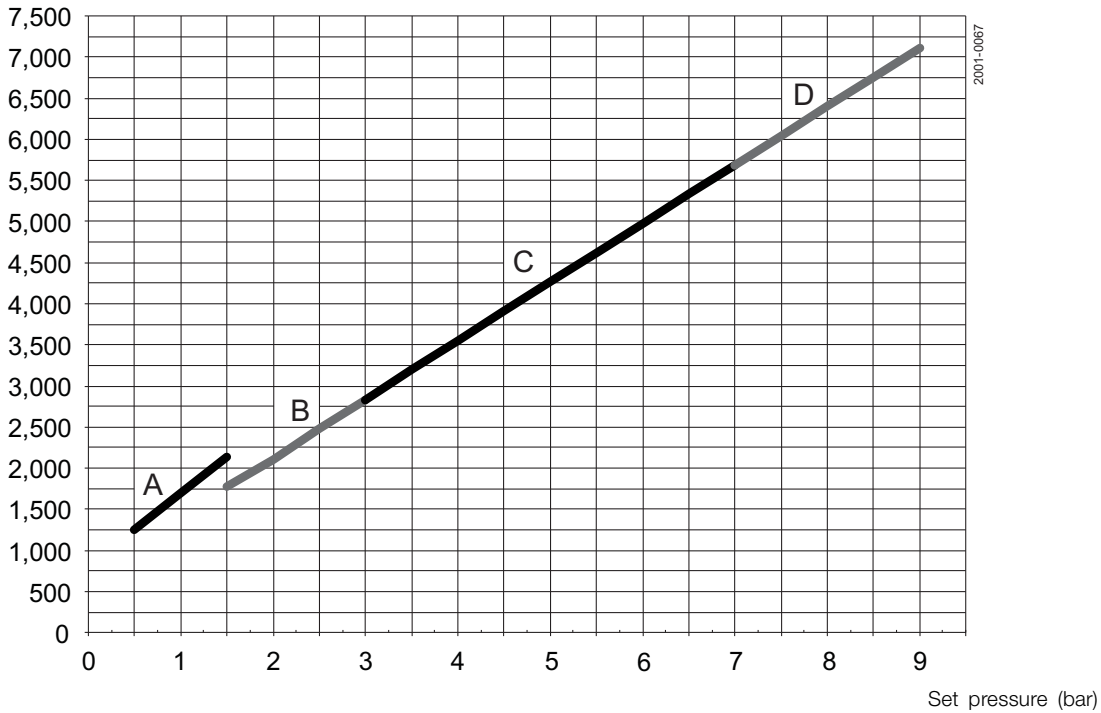

Pressure range [bar]

- A = 0.4 - 1.5
- B = 1.6 - 3.0
- C = 3.1 - 7.0
- D = 7.1 - 9.0

DN80 set pressure: 0.3 - 8.0 bar for liquids (water 20 °C)

Flow rate [m³/h].

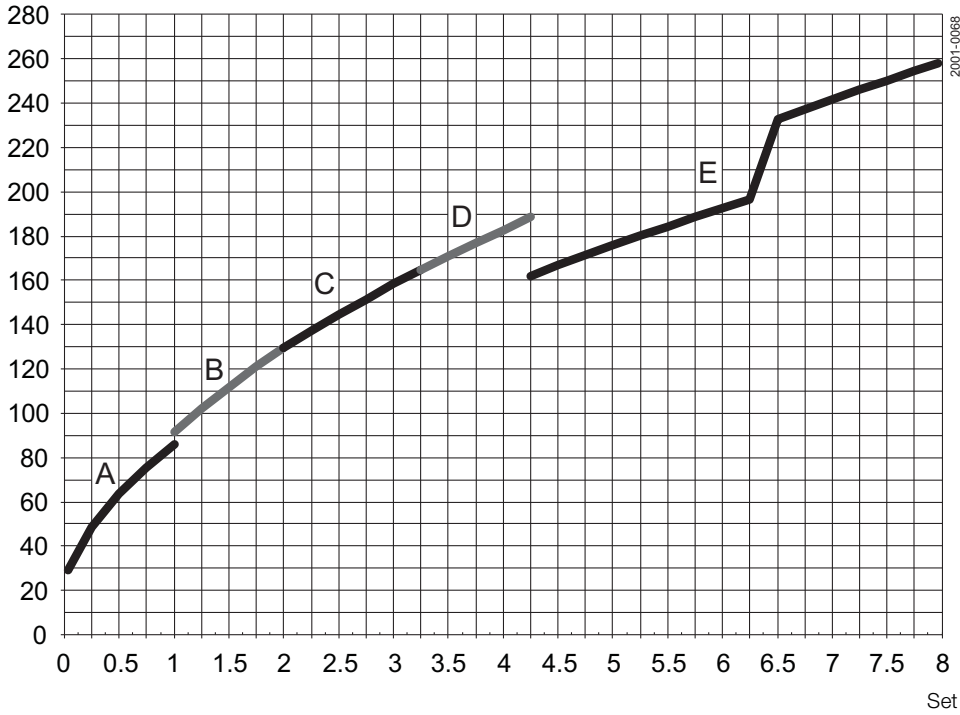

Pressure range [bar]

- A = 0.3 - 0.9
- B = 1.0 - 1.9
- C = 2.0 - 3.3
- D = 3.4 - 4.3
- E = 4.4 - 8.0

DN80 set pressure: 0.3 - 8.0 bar for gases (air 20 °C)

Flow rate [m³/h].

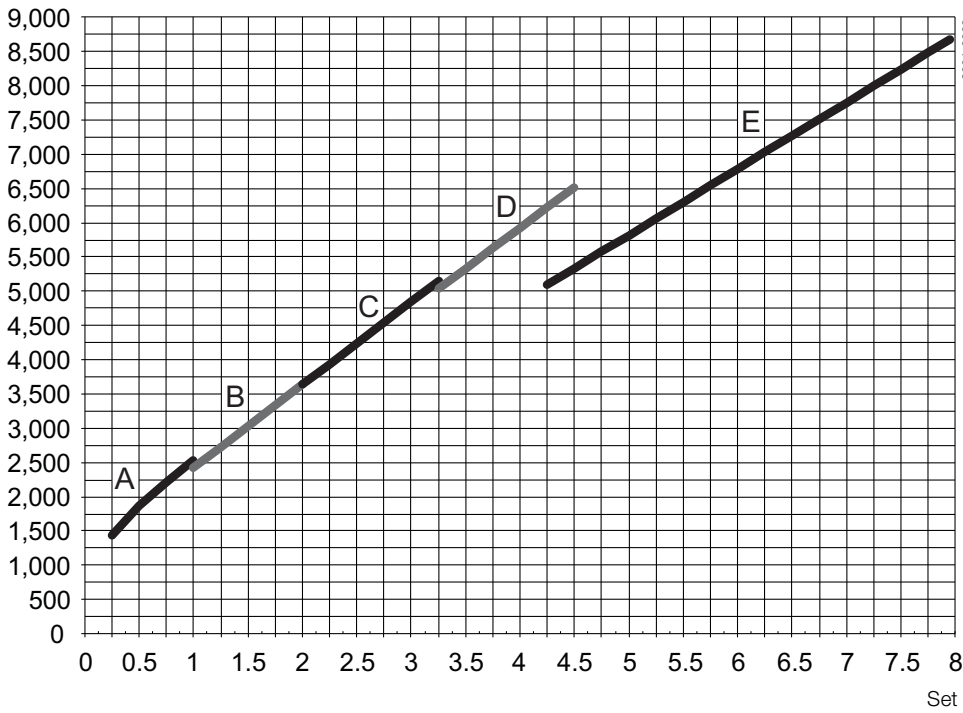

Pressure range [bar]

- A = 0.3 - 0.9
- B = 1.0 - 1.9
- C = 2.0 - 3.3
- D = 3.4 - 4.3
- E = 4.4 - 8.0

DN100 set pressure: 0.3 - 3.2 bar for liquids (water 20 °C)

Flow rate [m³/h].

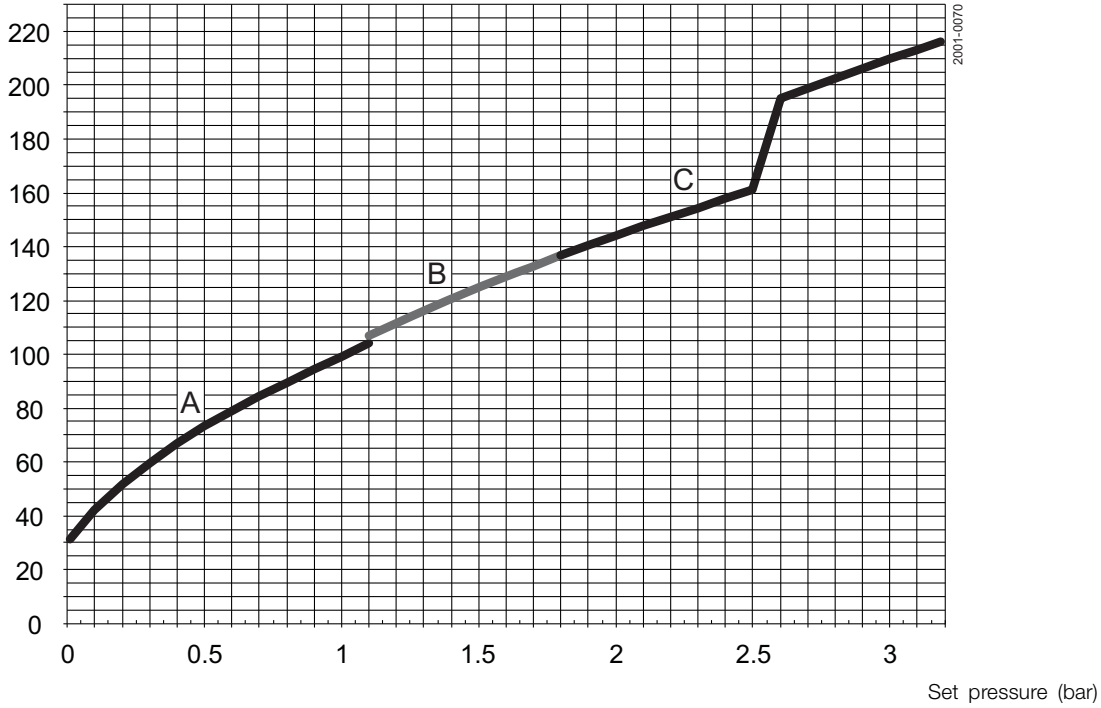

Pressure range [bar]

A = 0.3 - 1.1

B = 1.2 - 1.8

C = 1.9 - 3.2

DN100 set pressure: 0.3 - 3.2 bar for gases (air 20 °C)

Flow rate [m³/h].

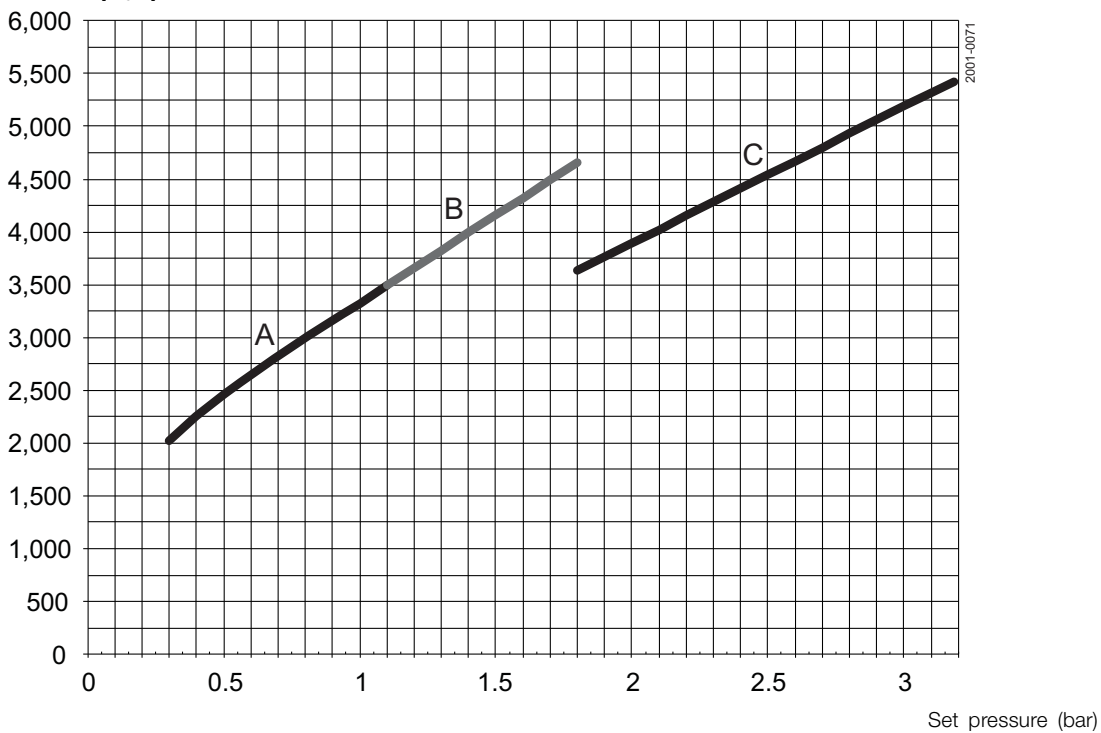

Pressure range [bar]

A = 0.3 - 1.1

B = 1.2 - 1.8

C = 1.9 - 3.2

Alfa Laval reserves the right to change specifications without prior notification.

How to contact Alfa Laval

Contact details for all countries are continually updated on our website. Please visit www.alfalaval.com to access the information direct.