



# Alfa Laval Unique DV-ST UltraPure

## Simply Unique Diaphragm Valves

### Concept

The standard Unique DV-ST UltraPure is designed either for manual operation or for Pneumatic operation. The valve consist of a valve body, diaphragm, handle or actuator. Optional Sensing and control units are available. With a fully modular design the Unique DV-ST UltraPure can be built to meet virtually any demand within most industries.

The valves are primarily used in biotech and pharmaceutical industries however they are also widely used in aseptic and hygienic processes as well as in utility systems within dairy, beverage and food industries.

### Working principle

Manual operation

A simple turn of the handle will push the compressor downwards on the diaphragm, pressing the diaphragm against the weir of the valve body thereby closing the valve

Pneumatic operation

The actuator controls the axial movement of a piston, thereby opening or closing the valve depending on the actuator function.

### Valve Body Design

The valve bodies are available in a wide variety of valve types and configuration options (dimension standards, connections, surface finish and material).

- 2-way
- T (Zero dead-leg design)
- Tank outlet
- Tandem
- Multi-port

Configurator available.

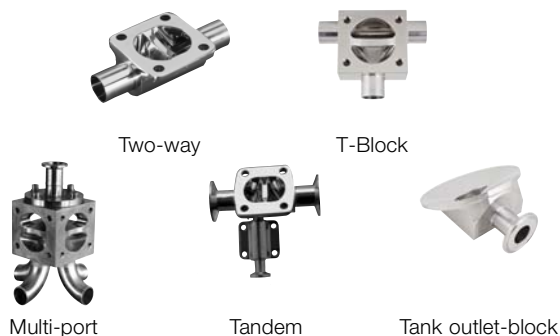

### Physical data

#### Materials

Body types	Cast	Forged	Block*
	CF3M (316L)	1.4435 (316L)	1.4435 (316L)
2-way	✓	✓	✓
T			✓
Tank outlet			✓
Tandem	✓	✓	✓
Multi-port			✓

\* Other materials on request

	Cast	Forged and block
Material	CF3M (316L)	1.4435 (316L)
Delta ferrite	< 2.0%	< 0.5%
Sulphur content	< 0.04%	0.005-0.017%
Internal surface finish	Ra < 0.51µm	Ra < 0.51µm
	Ra < 0.38µm EP <sup>1)</sup>	Ra < 0.38µm EP <sup>1)</sup>
External surface finish	Blasted	Blasted <sup>2)</sup>

<sup>1)</sup> Electro Polished

<sup>2)</sup> Block with external machined surface.

0.51µm = SF1, 0.38µm = SF4

**Sensing and control units:**

A wide range of sensing and control units are available for actuators consisting of:

- Controls unit
- Indication units
- ATEX units
- Stroke limiters

**Unique DV-ST Stainless Steel Actuator DN8-DN15 (1/4"-1/2")**

Adapter for mounting of ThinkTop V50, ThinkTop Basic, ThinkTop D30 and IndiTop - see automation accessories

**Documentation**

All UltraPure valves are delivered with our comprehensive Q-Doc documentation package, which includes:

- 3.1/ MTR traceability certificate corresponding to EN 10204
- FDA - Declaration of conformity to FDA (CFR 21: 177.2600 or 177.1550)
- USP - Certificate of conformity to USP Class VI (Chapter 88, biological reactivity test)
- TSE/ADI - Declaration (Transmissible Spongiform Encephalopathy/Animal Derived Ingredients)
- Surface finish conformity declaration

The following documentation is available upon request:

- Surface finish certificate (Ra test results)
- ATEX certificate

**Handle and actuator:**

The diaphragm valves can be operated by a handle or a pneumatic actuator. Alfa Laval offers 2 different types of manual handles and 1 type of pneumatic actuator.

**Actuator**



Model	SS
Sizes	DN 8 - 100 1/4" - 4"
Housing	Stainless steel
Intermediate part	Stainless steel
Compressor, stem	Stainless steel
Max. product working pressure, EPDM, PTFE/EPDM	10 bar
Max. product working pressure, TFM/EPDM	6 bar
Full Vacuum	✓
Max. air temperature	80°C
Max. air pressure	7 bar
ATEX,	✓ II 2G Ex h IIB T4 Gb (-10°C ≤ tamb ≤ 80°C) II 3D Ex h IIB T100°C Dc (-10°C ≤ tamb ≤ 80°C)
Autoclavable	✓
Leakage Detection	✓

1) 121°C for max. 60 min

**Handles**



Model	SS/SS	C/SS
Size	DN 8 - 100 1/4" - 4"	DN 8 - 100 1/4" - 4"
Handwheel	Stainless steel	PA 1)
Bonnet	Stainless steel	Stainless steel
Spindle + compressor <sup>1)</sup>	Stainless steel	Stainless steel
Max. product pressure	10 bar	10 bar
Overclosure protection	✓	✓
Optical positioner	✓	✓
Autoclavable	✓ 2)	✓ 2)
Leakage Detection	✓	✓

1) PA (polyamid)

2) 121°C for max. 60 min.

## Diaphragms



The diaphragms are available as soft elastomer (EPDM) as well as hard elastomers (PTFE/EPDM and TFM/EPDM).

The hard elastomers are supported by a soft elastomer (EPDM). The 2-piece design allows the two elastomers to work independently of each other, thereby reducing tension caused by different thermal properties.

Diaphragms are available with 3 different types of connections: thread, bayonet and button connection.

- Threaded connections are used on soft elastomers  $\geq$  DN 25 (1")
- Bayonet connections are used on all hard elastomer  $\geq$  DN 15 (1/2")
- Button connections are used on all small sizes.

## Material selection:

Each application has different working conditions and therefore different demands on the diaphragm. In order to select the most suitable diaphragm for your application, the following factors should be considered:

- Working pressure
- Application temperatures
- Process fluids (product, cleaning liquid, sterilisation, passivation, etc.)

Soft elastomer (EPDM) is suitable for most applications and for high working temperatures. Including continuous steam application.

Hard elastomers offer the highest possible degree of chemical resistance. Our TFM (PFTE grade) elastomer is a more flexible material and has some of the features of soft elastomer including for example low creep.

For further information, please see below or contact Alfa Laval for further guidance.

## Diaphragm properties:

Description	Temperature recommendations °C			Documentation			Available sizes	Available Diaphragm connections:		
	Min.	Max.	Max. Steam	FDA	USP	TSE		Button	Thread	Bayonet
EPDM	-40°C	130°C	150°C <sup>1)</sup>	✓	✓	✓	DN 8 - 100	DN 8 - 20	DN 25 - 100	
PTFE/EPDM	-5°C	175°C	150°C <sup>2)</sup>	✓	✓	✓	DN 15 - 100			DN 15 - 100
TFM/EPDM	-5°C	175°C	150°C <sup>2)</sup>	✓	✓	✓	DN 8 - 100	DN 8 - 10		DN 15 - 100

<sup>1)</sup> Continuous temperature

<sup>2)</sup> 40 min. steam sterilisation

<sup>3)</sup> < DN25 thread optional

FDA - Declaration of conformity to FDA (CFR 21: 177.2600 or 177.1550)

USP - Certificate of conformity to USP Class VI (chapter 88, biological reactivity test)

TSE/ADI Declaration (Transmissible Spongiform Encephalopathy /Animal Derived Ingredients)

Pressure drop / capacity table

Kv value (Pipe standard ISO 1127 / DIN/A)

Lift in %	kv in l/min. Δp = 1 bar								
	DN 8 (1/4")	DN 15 (1/2")	DN 20 (3/4")	DN 25 (1")	DN 40 (1 1/2")	DN 50 (2")	DN 65 (2 1/2")	DN 80 (3")	DN 100 (4")
100	27	70	146	218	684	1156	1571	2533	3415
90	27	68	140	210	667	1116	1480	2515	-
80	26	67	133	201	625	1076	1445	2462	-
70	25	64	124	194	610	994	1365	2312	-
60	23	59	101	165	545	893	1210	2170	-
50	20	47	87	142	457	750	1044	1925	-
40	18	35	55	115	345	606	835	1565	-
30	11	22	43	65	310	424	625	845	-
20	10	17	20	25	180	222	280	401	-
10	2	5	7	14	50	64	125	195	-

Kv value (Pipe standard ASME BPE)

Lift in %	kv in l/min. Δp = 1 bar								
	DN 8 (1/4")	DN 15 (1/2")	DN 20 (3/4")	DN 25 (1")	DN 40 (1 1/2")	DN 50 (2")	DN 65 (2 1/2")	DN 80 (3")	DN 100 (4")
100	3.4	35	99	180	426	914	1395	2066	3333
90	3.3	35	99	173	425	914	1394	2066	-
80	3.3	34	97	155	410	913	1393	2058	-
70	3.3	33	95	145	401	910	1311	2030	-
60	3.3	33	94	140	388	882	1210	1950	-
50	3.2	31	90	105	349	776	1090	1753	-
40	3.1	28	76	95	335	665	872	1445	-
30	3.1	19	65	66	265	525	630	940	-
20	3.0	10	45	48	139	370	250	300	-
10	2.6	3	10	10	22	67	88	142	-

$C_v = 1.16 \times K_v$

Note!

For the diagrams the following applies:

Medium: Water (20 °C)

Measurement: In accordance with VDI2173

Drain angle x :

Port size DN	ASME BPE Inch	ISO 2037	DIN11850 (Series A)	ISO 1127 (Series B)	
				ASME BPE	ISO 2037
8	1/4"	37°	27°	27°	22°
10	3/8"	33°	28°	28°	31°
15	1/2"	32°	23°	23°	18°
20	3/4"	26°	23°	23°	15°
25	1"	22°	25°	21°	20°
32	1 1/4"	-	-	21°	-
32	1 1/4"	-	-	-	18°
40	1 1/2"	24°	24°	22°	18°
50	2"	24°	24°	23°	20°
65	2 1/2"	20°	22°	19°	15°
80	3"	22°	25°	22°	15°
100	4"	14°	14°	13°	8°

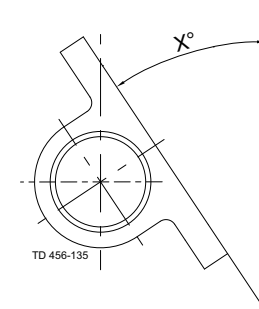

## 2-way bodies:

2-way bodies are the standard configuration for shut off and regulating functions.  
The 2-way bodies are available from forged or cast material.

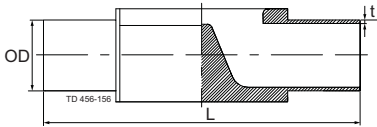

### Weld ends: (mm)

Port size		Length	ASME BPE	ISO 2037	DIN11850 <sup>1)</sup> (Series A)	ISO1127 <sup>1)</sup> (Series B)
DN	Inch	L	OD x t	OD x t	OD x t	OD x t
8	1/4"	89	6.35 x 0.89	12.00 x 1.00	10.00 x 1.00	13.50 x 1.60
10	3/8"	89	9.53 x 0.89	12.70 x 1.00	13.00 x 1.50	17.20 x 1.60
15	1/2"	89	12.70 x 1.65			
15	1/2"	110	12.70 x 1.65	17.20 x 1.00	19.00 x 1.50	21.30 x 1.60
20	3/4"	119	19.05 x 1.65	21.30 x 1.00	23.00 x 1.50	26.90 x 1.60
25	1"	129	25.40 x 1.65	25.00 x 1.20	29.00 x 1.50	33.70 x 2.00
32	1 1/4"	129	-	-	35.00 x 1.50	
32	1 1/4"	161	-	-		42.40 x 2.00
40	1 1/2"	161	38.10 x 1.65	38.00 x 1.20	41.00 x 1.50	48.30 x 2.00
50	2"	192	50.80 x 1.65	51.00 x 1.20	53.00 x 1.50	60.30 x 2.00
65	2 1/2"	218	63.50 x 1.65	63.50 x 1.60	70.00 x 2.00	76.10 x 2.00
80	3"	256	76.20 x 1.65	76.10 x 1.60	85.00 x 2.00	88.90 x 2.30
100	4"	218	101.60 x 2.11	101.60 x 2.00	104.00 x 2.00	114.30 x 2.30

<sup>1)</sup> Forged only

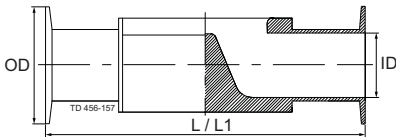

### Clamp ends: (mm)

Port size		Length	Length	Clamp ASME BPE		Clamp ISO 2852		Clamp DIN 32676 <sup>1)</sup>		Clamp DIN 32676 <sup>1)</sup>	
DN	Inch	L <sup>3)</sup>	L <sup>1)2)</sup>	for ASME BPE		for ISO 2037		for Series A/DIN		for Series B/ISO	
				OD	ID	OD	ID	OD	ID	OD	ID
8	1/4"	89	63.5	25.00	4.57			25.00	8.00	25.0	10.3
10	3/8"	89	63.5	25.00	7.75			34.00	10.00		
15	1/2"	-	63.5	25.00	9.40						
10	3/8"	108								25.0	14.0
15	1/2"	108	89	25.00	9.40			34.00	16.00	50.5	18.1
20	3/4"	118	102	25.00	15.75			34.00	20.00	50.5	23.7
25	1"	127	114	50.50	22.10	50.50	22.60	50.50	26.00	50.5	29.7
32	1 1/4"	127						50.50	32.00		
32	1 1/4"	159								64.0	38.4
40	1 1/2"	159	140	50.50	34.80	50.50	35.60	50.50	38.00	64.0	44.3
50	2"	191	159	64.00	47.50	64.00	48.60	64.00	50.00	77.5	56.3 <sup>1)</sup>
65	2 1/2"	216	194	77.50	60.20	77.50	60.30	91.00	66.00	91.0	72.1
80	3"	254	222	91.00	72.90	91.00	72.90	106.00	81.00	106.0	84.3
100	4"	305	-	118.92	97.38	119.00	97.60	119.00	100.00	119.00	109.7

<sup>1)</sup> Forged only

<sup>2)</sup> ASME BPE forged valves only, short version acc. to ASME BPE dimension table for hygienic clamp joint: Weir style diaphragm valve

<sup>3)</sup> Standard build-in length acc. EN 558-1, Series 7

Other sizes and connections available on request.

### T- bodies:

T are constructed with weir as close as possible to the internal contour of the main tube thereby minimising potential dead leg. The T- bodies are available as machined from block or from forged material.



Dimension table for T-block bodies - ASME

Main tube DN	Valve DN	Main tube OD x t mm	Valve OD1 x t mm	B - Weld mm	B - Clamp mm	C mm	L - Weld mm	L - Clamp mm
8	8	ø6.35x0.89	ø6.35x0.89	34.9	47.6	0.0	57.0	82.4
10	8	ø9.53x0.89	ø6.35x0.89	35.6	48.3	3.2	57.0	82.4
15	8	ø12.7x1.65	ø6.35x0.89	37.0	49.7	4.6	81.0	106.4
20	8	ø19.05x1.65	ø6.35x0.89	39.9	52.6	9.0	81.0	106.4
25	8	ø25.4x1.65	ø6.35x0.89	43.2	55.9	12.3	81.0	106.4
40	8	ø38.1x1.65	ø6.35x0.89	55.4	68.1	13.0	81.0	106.4
50	8	ø50.8x1.65	ø6.35x0.89	57.7	70.4	19.4	81.0	106.4
65	8	ø63.5x1.65	ø6.35x0.89	63.5	76.2	25.8	81.0	106.4
80	8	ø76.2x1.65	ø6.35x0.89	70.2	88.9	32.1	81.0	106.4
10	10	ø9.53x0.89	ø9.53x0.89	35.6	48.3	3.2	57.0	82.4
15	10	ø12.7x1.65	ø9.53x0.89	37.0	49.7	4.6	81.0	106.4
20	10	ø19.05x1.65	ø9.53x0.89	39.9	52.6	9.0	81.0	106.4
25	10	ø25.4x1.65	ø9.53x0.89	43.2	55.9	12.3	81.0	106.4
40	10	ø38.1x1.65	ø9.53x0.89	55.4	68.1	13.0	81.0	106.4
50	10	ø50.8x1.65	ø9.53x0.89	57.7	70.4	19.4	81.0	106.4
65	10	ø63.5x1.65	ø9.53x0.89	69.5	76.2	25.8	81.0	106.4
80	10	ø76.2x1.65	ø9.53x0.89	70.2	82.9	32.1	81.0	106.4
15	15	ø12.7x1.65	ø12.7x1.65	57.7	70.4	3.6	95.0	120.4
20	15	ø19.05x1.65	ø12.7x1.65	58.6	71.3	8.0	95.0	120.4
25	15	ø25.4x1.65	ø12.7x1.65	62.0	74.7	11.3	95.0	120.4
40	15	ø38.1x1.65	ø12.7x1.65	68.6	81.3	16.95	95.0	120.4
50	15	ø50.8x1.65	ø12.7x1.65	75.2	87.9	20.6	95.0	120.4
65	15	ø63.5x1.65	ø12.7x1.65	81.8	94.5	24.75	95.0	120.4
80	15	ø76.2x1.65	ø12.7x1.65	88.3	101.0	29.1	95.0	120.4
20	20	ø19.05x1.65	ø19.05x1.65	64.9	77.6	1.0	109.0	134.4
25	20	ø25.4x1.65	ø19.05x1.65	68.4	81.1	6.3	109.0	134.4
40	20	ø38.1x1.65	ø19.05x1.65	75.1	87.8	13.0	109.0	134.4
50	20	ø50.8x1.65	ø19.05x1.65	81.7	94.4	17.6	109.0	134.4
65	20	ø63.5x1.65	ø19.05x1.65	88.2	100.9	21.2	109.0	134.4
80	20	ø76.2x1.65	ø19.05x1.65	94.8	107.5	24.9	109.0	134.4
25	25	ø25.4x1.65	ø25.4x1.65	72.9	85.6	4.3	117.0	142.4
40	25	ø38.1x1.65	ø25.4x1.65	79.6	92.3	12.4	117.0	142.4
50	25	ø50.8x1.65	ø25.4x1.65	85.3	98.0	18.1	117.0	142.4
65	25	ø63.5x1.65	ø25.4x1.65	91.9	104.6	22.2	117.0	142.4
80	25	ø76.2x1.65	ø25.4x1.65	98.4	111.1	25.9	117.0	142.4
40	40	ø38.1x1.65	ø38.1x1.65	88.9	101.6	2.4	143.0	168.4
50	40	ø50.8x1.65	ø38.1x1.65	95.8	108.5	11.3	143.0	168.4
65	40	ø63.5x1.65	ø38.1x1.65	102.4	115.1	17.6	143.0	168.4
80	40	ø76.2x1.65	ø38.1x1.65	109.1	121.8	22.6	143.0	168.4
50	50	ø50.8x1.65	ø50.8x1.65	111.5	124.2	4.6	170.0	195.4
65	50	ø63.5x1.65	ø50.8x1.65	111.7	124.4	12.8	170.0	195.4
80	50	ø76.2x1.65	ø50.8x1.65	118.4	131.1	18.9	170.0	195.4
65	65	ø63.5x1.65	ø63.5x1.65	134.4	147.1	12.7	190.0	215.4
80	65	ø76.2x1.65	ø63.5x1.65	134.5	147.2	12.9	190.0	215.4
80	80	ø76.2x1.65	ø76.2x1.65	152.1	164.8	9.9	233.0	258.4

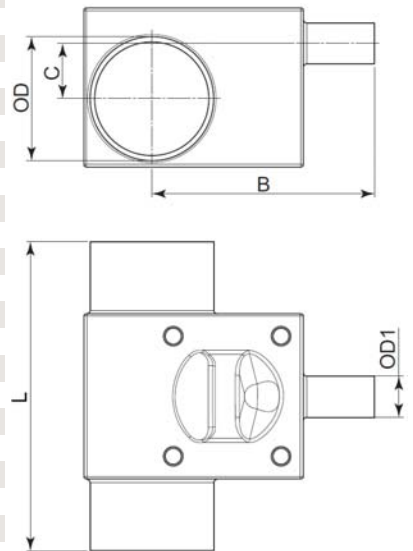

Note: Contact Alfa Laval for 4" T-block valves

T-block valves are available in all dimension standards(ASME, DIN, ISO2037, ISO1127) Hybrid solutions with mixed dimension standards (ASME, DIN, ISO2037, ISO1127) is furthermore possible, please contact Alfa Laval".

**Tank outlet body:**

Tank outlet bodies with minimised dead leg and complete drainability. The tank outlet valve bodies are available as machined from block or from forged material.



**Dimension table for Tank outlet-block bodies - all standards**

DN	ØA (mm)	B (mm)	R
DN15 (1/2")	90	5.4	144°
DN20 (3/4")	100	5.4	144°
DN25 (1")	120	5.4	144°
DN40 (1½")	150	5.4	144°
DN50 (2")	180	5.4	144°
DN65 (2½")	200	5.4	144°
DN80 (3")	250	5.4	144°

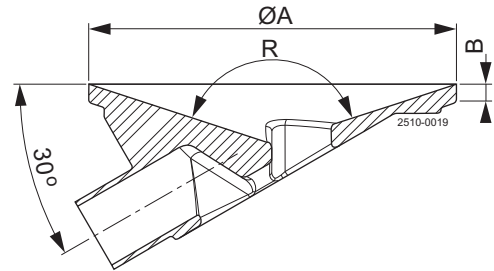

For OD dimensions see two-way valves.  
Note: Contact Alfa Laval for 4" T-block valves

**Tandem body:**

Tandem bodies are available in a wide variety of angles and positions for sampling or steam purposes. The Tandem bodies are available from forged or cast material.

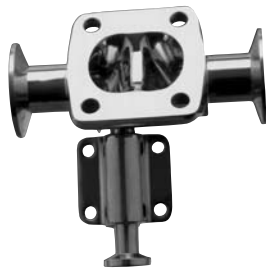

**Multi-port body:**

Multi-port bodies are a space and time saving alternative to valve clusters minimising dead volumes. Alfa Laval offers customised solutions for both simple and complex processes.



For more details, please contact Alfa Laval.

**Tandem body configuration**

To configure the tandem body the position and the angle of the two bodies are selected by combining one of the letters with one of the numbers in the following overview.

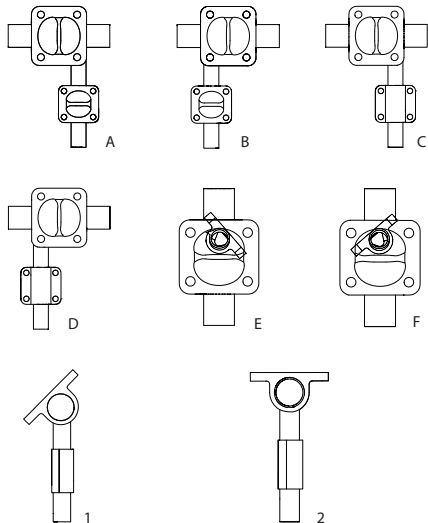

Alfa Laval reserves the right to change specifications without prior notification.

---

**How to contact Alfa Laval**

Contact details for all countries  
are continually updated on our website.  
Please visit [www.alfalaval.com](http://www.alfalaval.com) to  
access the information direct.